

74ABT823

9-bit D-type flip-flop with reset and enable; 3-state

Rev. 02 — 7 February 2005

Product data sheet

1. General description

The 74ABT823 bus interface register is designed to eliminate the extra packages required to buffer existing registers and provide extra data width for wider data and address paths of buses carrying parity.

The 74ABT823 is a 9-bit wide buffered register with clock enable input (\overline{CE}) and master reset input (\overline{MR}) which are ideal for parity bus interfacing in systems using many microprocessors.

The register is fully edge-triggered. The state of each D input, one set-up time before the LOW-to-HIGH clock transition, is transferred to the corresponding output Q of the flip-flop.

2. Features

- High-speed parallel registers with positive edge-triggered D-type flip-flops
- Ideal where high speed, light loading, or increased fan-in are required with MOS microprocessors
- Output capability: +64 mA and -32 mA
- Latch-up protection:
 - ◆ JESD78: exceeds 500 mA
- ESD protection:
 - ◆ MIL STD 883 method 3015: exceeds 2000 V
 - ◆ Machine model: exceeds 200 V
- Power-on 3-state
- Power-on reset

3. Quick reference data

Table 1: Quick reference data

$GND = 0\text{ V}$; $T_{amb} = 25\text{ }^\circ\text{C}$.

Symbol	Parameter	Conditions	Min	Typ	Max	Unit
t_{PLH}	propagation delay CP to Qn	$C_L = 50\text{ pF}$; $V_{CC} = 5\text{ V}$	-	4.3	-	ns
t_{PHL}	propagation delay CP to Qn	$C_L = 50\text{ pF}$; $V_{CC} = 5\text{ V}$	-	4.4	-	ns
C_I	input capacitance	$V_I = 0\text{ V}$ or V_{CC}	-	4	-	pF
C_O	output capacitance	outputs disabled; $V_O = 0\text{ V}$ or V_{CC}	-	7	-	pF
I_{CC}	quiescent supply current	outputs 3-state; $V_{CC} = 5.5\text{ V}$; $V_I = GND$ or V_{CC}	-	0.5	-	μA

PHILIPS

4. Ordering information

Table 2: Ordering information

Type number	Package			Version
	Temperature range	Name	Description	
74ABT823N	-40 °C to +85 °C	DIP24	plastic dual in-line package; 24 leads (300 mil)	SOT222-1
74ABT823D	-40 °C to +85 °C	SO24	plastic small outline package; 24 leads; body width 7.5 mm	SOT137-1
74ABT823DB	-40 °C to +85 °C	SSOP24	plastic shrink small outline package; 24 leads; body width 5.3 mm	SOT340-1
74ABT823PW	-40 °C to +85 °C	TSSOP24	plastic thin shrink small outline package; 24 leads; body width 4.4 mm	SOT355-1

5. Functional diagram

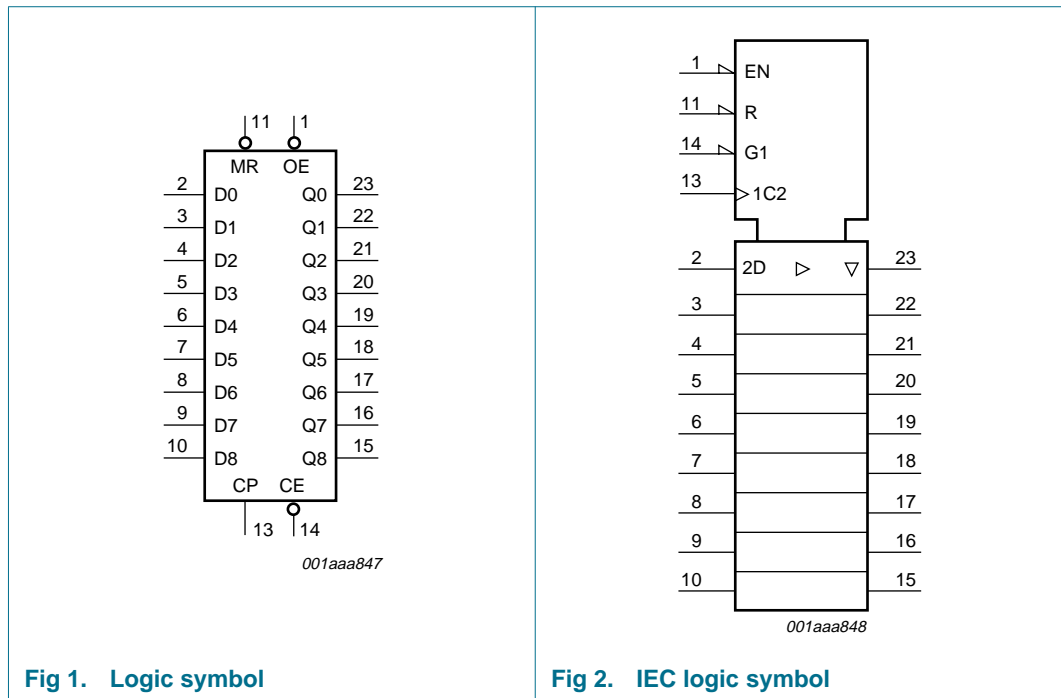

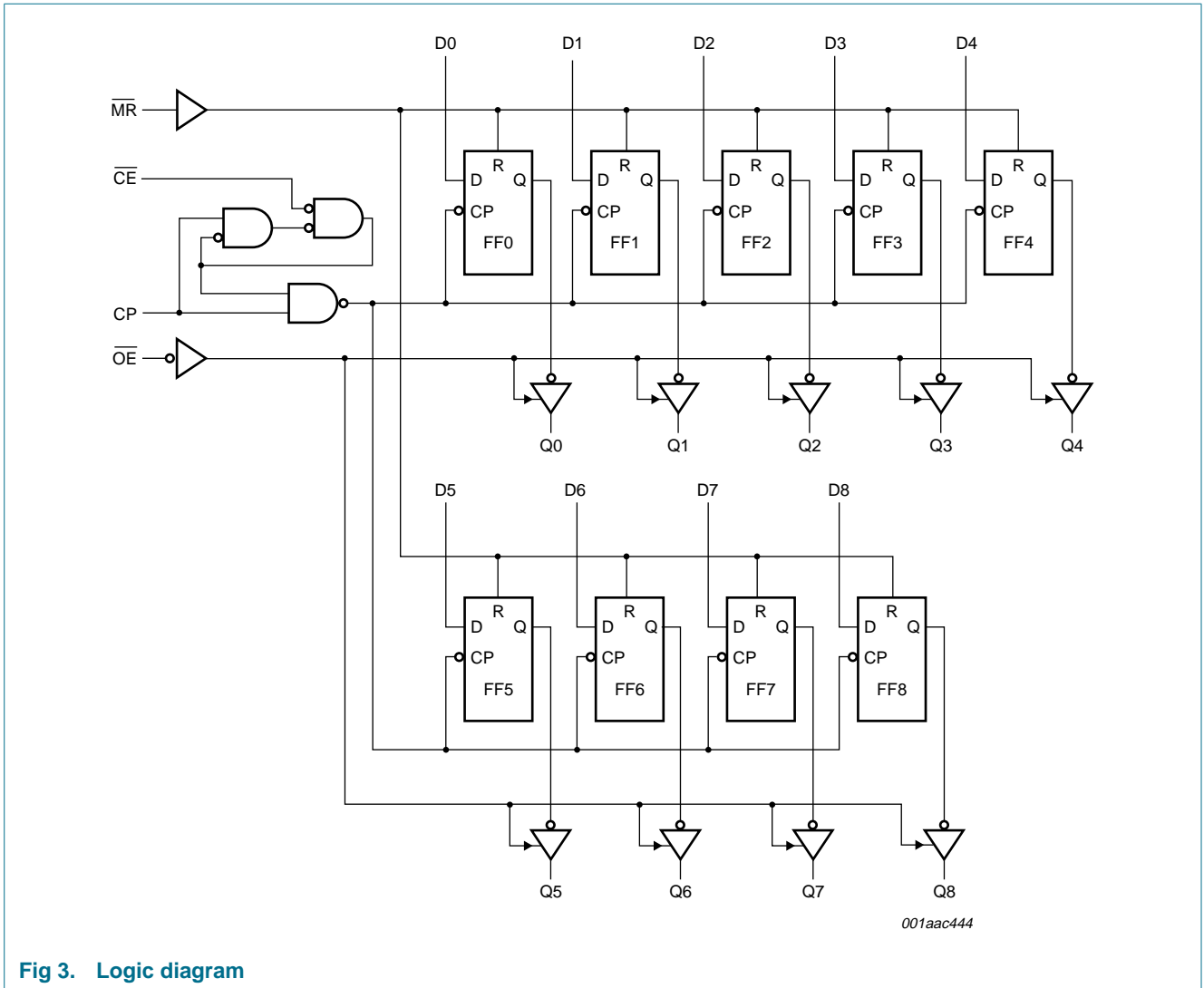
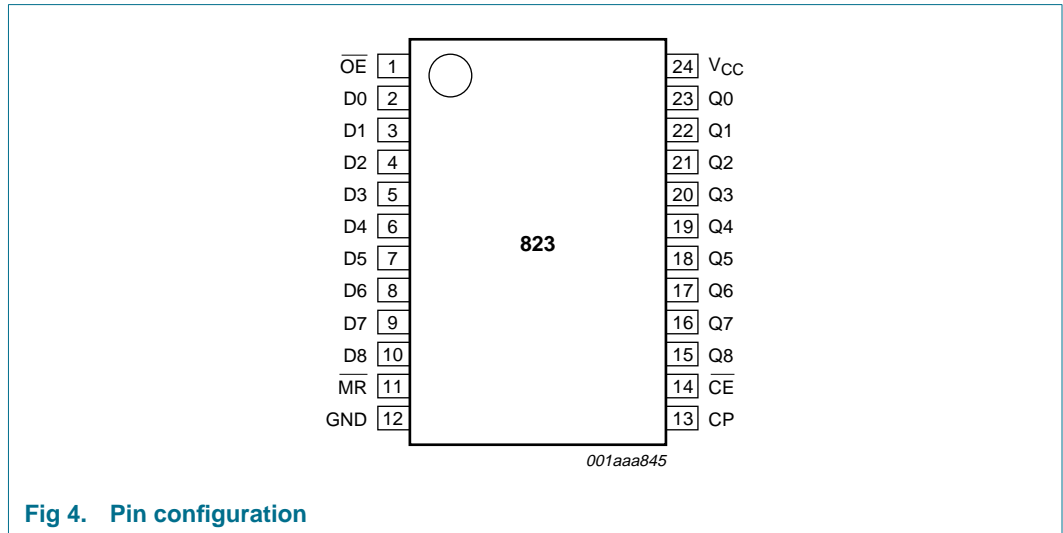

Fig 3. Logic diagram

6. Pinning information

6.1 Pinning



6.2 Pin description

Table 3: Pin description

Symbol	Pin	Description
\overline{OE}	1	output enable input (active LOW)
D0	2	data input 0
D1	3	data input 1
D2	4	data input 2
D3	5	data input 3
D4	6	data input 4
D5	7	data input 5
D6	8	data input 6
D7	9	data input 7
D8	10	data input 8
\overline{MR}	11	master reset input (active LOW)
GND	12	ground (0 V)
CP	13	clock pulse input (active rising edge)
\overline{CE}	14	clock enable input (active LOW)
Q8	15	data output 8
Q7	16	data output 7
Q6	17	data output 6
Q5	18	data output 5
Q4	19	data output 4
Q3	20	data output 3
Q2	21	data output 2

Table 3: Pin description ...continued

Symbol	Pin	Description
Q1	22	data output 1
Q0	23	data output 0
V _{CC}	24	positive supply voltage

7. Functional description

7.1 Function table

Table 4: Function table [1]

Operating mode	Input					Output	
	OE	MR	CE	CP	Dn	Qn	
Clear	L	L	X	X	X	L	
Load and read data	L	H	L	↑	h	H	
					l	L	
Hold	L	H	H	NC	X	NC	
High-impedance	H	X	X	X	X	Z	

- [1] H = HIGH voltage level;
 L = LOW voltage level;
 h = HIGH voltage level one set-up time prior to the LOW-to-HIGH clock transition;
 l = LOW voltage level one set-up time prior to the LOW-to-HIGH clock transition;
 ↑ = LOW-to-HIGH clock transition;
 NC = no change;
 X = don't care;
 Z = high-impedance OFF-state.

8. Limiting values

Table 5: Limiting values

In accordance with the Absolute Maximum Rating System (IEC 60134). Voltages are referenced to GND (ground = 0 V).

Symbol	Parameter	Conditions	Min	Max	Unit
V_{CC}	supply voltage		-0.5	+7.0	V
V_I	input voltage		[1] -1.2	+7.0	V
V_O	output voltage	output in OFF-state or HIGH-state	[1] -0.5	+5.5	V
I_{IK}	input diode current	$V_I < 0$ V	-	-18	mA
I_{OK}	output diode current	$V_O < 0$ V	-	-50	mA
I_O	output current	output in LOW-state	-	128	mA
T_j	junction temperature		[2] -	150	°C
T_{stg}	storage temperature		-65	+150	°C

[1] The input and output voltage ratings may be exceeded if the input and output current ratings are observed.

[2] The performance capability of a high-performance integrated circuit in conjunction with its thermal environment can create junction temperatures which are detrimental to reliability. The maximum junction temperature of this integrated circuit should not exceed 150 °C.

9. Recommended operating conditions

Table 6: Recommended operating conditions

Symbol	Parameter	Conditions	Min	Typ	Max	Unit
V_{CC}	supply voltage		4.5	-	5.5	V
V_I	input voltage		0	-	V_{CC}	V
V_{IH}	HIGH-level input voltage		2.0	-	-	V
V_{IL}	LOW-level input voltage		-	-	0.8	V
I_{OH}	HIGH-level output current		-	-	-32	mA
I_{OL}	LOW-level output current		-	-	64	mA
$\Delta t/\Delta V$	input transition rise or fall rate		0	-	5	ns/V
T_{amb}	ambient temperature	in free air	-40	-	+85	°C

10. Static characteristics

Table 7: Static characteristics

At recommended operating conditions; voltages are referenced to GND (ground = 0 V).

Symbol	Parameter	Conditions	Min	Typ	Max	Unit
T_{amb} = 25 °C						
V _{IK}	input diode voltage	V _{CC} = 4.5 V; I _{IK} = -18 mA	-	-0.9	-1.2	V
V _{OH}	HIGH-level output voltage	V _I = V _{IL} or V _{IH}				
		V _{CC} = 4.5 V; I _{OH} = -3 mA	2.5	2.9	-	V
		V _{CC} = 4.5 V; I _{OH} = -32 mA	2.0	2.4	-	V
		V _{CC} = 5.0 V; I _{OH} = -3 mA	3.0	3.4	-	V
V _{OL}	LOW-level output voltage	V _{CC} = 4.5 V; I _{OL} = 64 mA; V _I = V _{IL} or V _{IH}	-	0.42	0.55	V
V _{RST}	restart LOW-level output voltage	V _{CC} = 5.5 V; I _O = 1 mA; V _I = GND or V _{CC}	[1]	-	0.13	0.55 V
I _{LI}	input leakage current	V _{CC} = 5.5 V; V _I = GND or 5.5 V	-	±0.01	±1.0	µA
I _{OFF}	power-down leakage current	V _{CC} = 0.0 V; V _O or V _I ≤ 4.5 V	-	±5.0	±100	µA
I _{PU} , I _{PD}	power-up or power-down down 3-state output current	V _{CC} = 2.0 V; V _O = 0.5 V; V _I = GND or V _{CC} ; V _{OE} = V _{CC}	[2]	-	±5.0	±50 µA
I _{OZ}	3-state output current	V _{CC} = 5.5 V; V _I = V _{IL} or V _{IH}				
		output HIGH-state at V _O = 2.7 V	-	5.0	50	µA
		output LOW-state at V _O = 0.5 V	-	-5.0	-50	µA
I _{CEx}	output HIGH-state leakage current	V _{CC} = 5.5 V; V _O = 5.5 V; V _I = GND or V _{CC}	-	5.0	50	µA
I _O	output current	V _{CC} = 5.5 V; V _O = 2.5 V	[3]	-50	-100	-180 mA
I _{CC}	quiescent supply current	V _{CC} = 5.5 V; V _I = GND or V _{CC}				
		outputs HIGH-state	-	0.5	250	µA
		outputs LOW-state	-	27	34	mA
		outputs 3-state	-	0.5	250	µA
ΔI _{CC}	additional quiescent supply current per input pin	V _{CC} = 5.5 V; one input at 3.4 V and other inputs at V _{CC} or GND	[4]	-	0.5	1.5 mA
C _I	input capacitance	V _I = 0 V or V _{CC}	-	4	-	pF
C _O	output capacitance	outputs disabled; V _O = 0 V or V _{CC}	-	7	-	pF
T_{amb} = -40 °C to +85 °C						
V _{IK}	input diode voltage	V _{CC} = 4.5 V; I _{IK} = -18 mA	-	-	-1.2	V
V _{OH}	HIGH-level output voltage	V _I = V _{IL} or V _{IH}				
		V _{CC} = 4.5 V; I _{OH} = -3 mA	2.5	-	-	V
		V _{CC} = 4.5 V; I _{OH} = -32 mA	2.0	-	-	V
		V _{CC} = 5.0 V; I _{OH} = -3 mA	3.0	-	-	V
V _{OL}	LOW-level output voltage	V _{CC} = 4.5 V; I _{OL} = 64 mA; V _I = V _{IL} or V _{IH}	-	-	0.55	V
V _{RST}	restart LOW-level output voltage	V _{CC} = 5.5 V; I _O = 1 mA; V _I = GND or V _{CC}	[1]	-	-	0.55 V
I _{LI}	input leakage current	V _{CC} = 5.5 V; V _I = GND or 5.5 V	-	-	±1.0	µA
I _{OFF}	power-down leakage current	V _{CC} = 0.0 V; V _O or V _I ≤ 4.5 V	-	-	±100	µA
I _{PU} , I _{PD}	power-up or power-down down 3-state output current	V _{CC} = 2.0 V; V _O = 0.5 V; V _I = GND or V _{CC} ; V _{OE} = V _{CC}	[2]	-	-	±50 µA

Table 7: Static characteristics ...continued

At recommended operating conditions; voltages are referenced to GND (ground = 0 V).

Symbol	Parameter	Conditions	Min	Typ	Max	Unit	
I _{OZ}	3-state output current	V _{CC} = 5.5 V; V _I = V _{IL} or V _{IH}		-			
		output HIGH-state at V _O = 2.7 V	-	-	50	μA	
		output LOW-state at V _O = 0.5 V	-	-	-50	μA	
I _{CEX}	output HIGH-state leakage current	V _{CC} = 5.5 V; V _O = 5.5 V; V _I = GND or V _{CC}	-	-	50	μA	
I _O	output current	V _{CC} = 5.5 V; V _O = 2.5 V	[3]	-50	-	-180	mA
I _{CC}	quiescent supply current	V _{CC} = 5.5 V; V _I = GND or V _{CC}		-			
		outputs HIGH-state	-	-	250	μA	
		outputs LOW-state	-	-	34	mA	
		outputs 3-state	-	-	250	μA	
ΔI _{CC}	additional quiescent supply current per input pin	V _{CC} = 5.5 V; one input at 3.4 V and other inputs at V _{CC} or GND	[4]	-	-	1.5	mA

- [1] For valid test results, data must not be loaded into the flip-flops (or latches) after applying the power.
- [2] This parameter is valid for any V_{CC} between 0 V and 2.1 V with a transition time of up to 10 ms. For V_{CC} = 2.1 V to V_{CC} = 5 V ± 10 %, a transition time of up to 100 μs is permitted.
- [3] Not more than one output should be tested at a time, and the duration of the test should not exceed one second.
- [4] This is the increase in supply current for each input at 3.4 V.

11. Dynamic characteristics

Table 8: Dynamic characteristics

GND = 0 V; for test circuit see [Figure 9](#).

Symbol	Parameter	Conditions	Min	Typ	Max	Unit	
T_{amb} = 25 °C; V_{CC} = 5 V							
t _{PLH}	propagation delay CP to Qn	see Figure 5	2.1	4.3	5.9	ns	
t _{PHL}	propagation delay	CP to Qn	see Figure 5	2.2	4.4	6.1	ns
		MR to Qn	see Figure 6	2.0	4.1	6.3	ns
t _{PZH}	output enable time to HIGH-level	see Figure 8	1.0	3.0	4.5	ns	
t _{PZL}	output enable time to LOW-level	see Figure 8	2.2	4.1	5.6	ns	
t _{PHZ}	output disable time from HIGH-level	see Figure 8	2.7	4.8	6.2	ns	
t _{PLZ}	output disable time from LOW-level	see Figure 8	2.5	5.0	6.4	ns	
t _{WH}	pulse width HIGH of CP	see Figure 5	2.9	1.9	-	ns	
t _{WL}	pulse width LOW	clock pulse CP	see Figure 5	3.8	2.8	-	ns
		master reset $\overline{\text{MR}}$	see Figure 6	5.5	4.0	-	ns
t _{SU(H)}	set-up time HIGH	Dn to CP	see Figure 7	2.1	0.5	-	ns
		$\overline{\text{CE}}$ to CP	see Figure 7	2.0	-0.5	-	ns

Table 8: Dynamic characteristics ...continued
GND = 0 V; for test circuit see Figure 9.

Symbol	Parameter	Conditions	Min	Typ	Max	Unit
$t_{su(L)}$	set-up time LOW					
	Dn to CP	see Figure 7	2.1	0.2	-	ns
	\overline{CE} to CP	see Figure 7	3.3	1.5	-	ns
$t_{h(H)}$	hold time HIGH					
	Dn to CP	see Figure 7	1.3	0.0	-	ns
	\overline{CE} to CP	see Figure 7	1.0	-1.4	-	ns
$t_{h(L)}$	hold time LOW					
	Dn to CP	see Figure 7	1.3	-0.3	-	ns
	\overline{CE} to CP	see Figure 7	2.0	0.7	-	ns
t_{rec}	recovery time \overline{MR} to CP	see Figure 6	2.5	0.6	-	ns
f_{max}	maximum clock frequency	see Figure 5	125	200	-	MHz
$T_{amb} = -40\text{ }^{\circ}\text{C to }+85\text{ }^{\circ}\text{C}; V_{CC} = 5\text{ V} \pm 0.5\text{ V}$						
t_{PLH}	propagation delay CP to Qn	see Figure 5	2.1	-	6.8	ns
t_{PHL}	propagation delay					
	CP to Qn	see Figure 5	2.2	-	6.7	ns
	MR to Qn	see Figure 6	2.0	-	7.1	ns
t_{PZH}	output enable time to HIGH-level	see Figure 8	1.0	-	5.3	ns
t_{PZL}	output enable time to LOW-level	see Figure 8	2.2	-	6.3	ns
t_{PHZ}	output disable time from HIGH-level	see Figure 8	2.7	-	6.9	ns
t_{PLZ}	output disable time from LOW-level	see Figure 8	2.5	-	6.9	ns
t_{WH}	pulse width HIGH of CP	see Figure 5	2.9	-	-	ns
t_{WL}	pulse width LOW					
	clock pulse CP	see Figure 5	3.8	-	-	ns
	master reset \overline{MR}	see Figure 6	5.5	-	-	ns
$t_{su(H)}$	set-up time HIGH					
	Dn to CP	see Figure 7	2.1	-	-	ns
	\overline{CE} to CP	see Figure 7	2.0	-	-	ns
$t_{su(L)}$	set-up time LOW					
	Dn to CP	see Figure 7	2.1	-	-	ns
	\overline{CE} to CP	see Figure 7	3.3	-	-	ns
$t_{h(H)}$	hold time HIGH					
	Dn to CP	see Figure 7	1.3	-	-	ns
	\overline{CE} to CP	see Figure 7	1.0	-	-	ns
$t_{h(L)}$	hold time LOW					
	Dn to CP	see Figure 7	1.3	-	-	ns
	\overline{CE} to CP	see Figure 7	2.0	-	-	ns
t_{rec}	recovery time \overline{MR} to CP	see Figure 6	2.5	-	-	ns
f_{max}	maximum clock frequency	see Figure 5	125	-	-	MHz

12. Waveforms

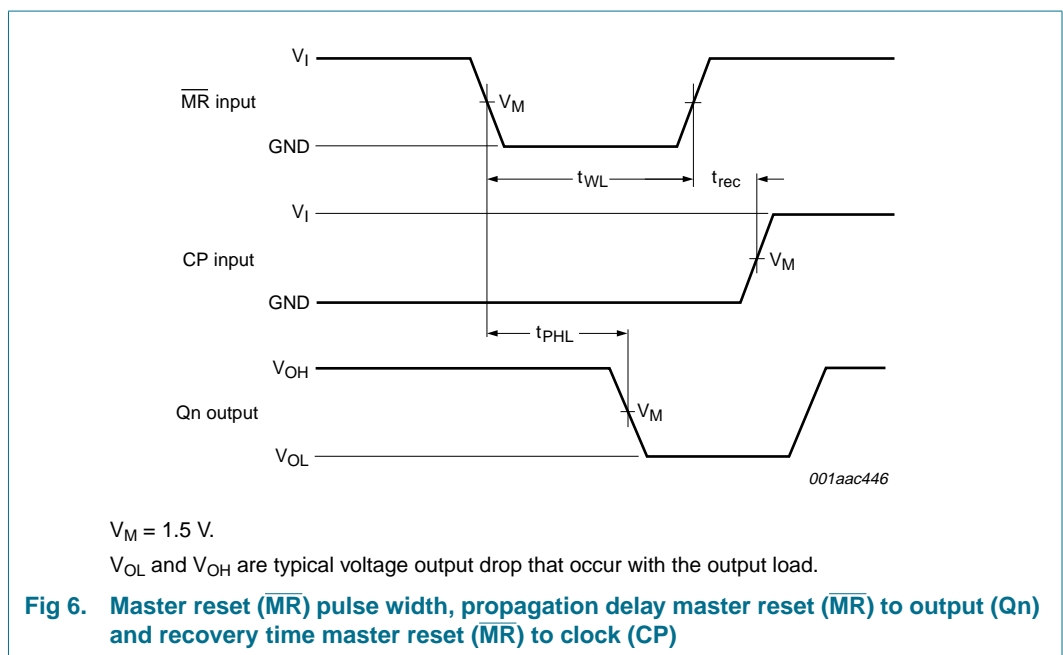
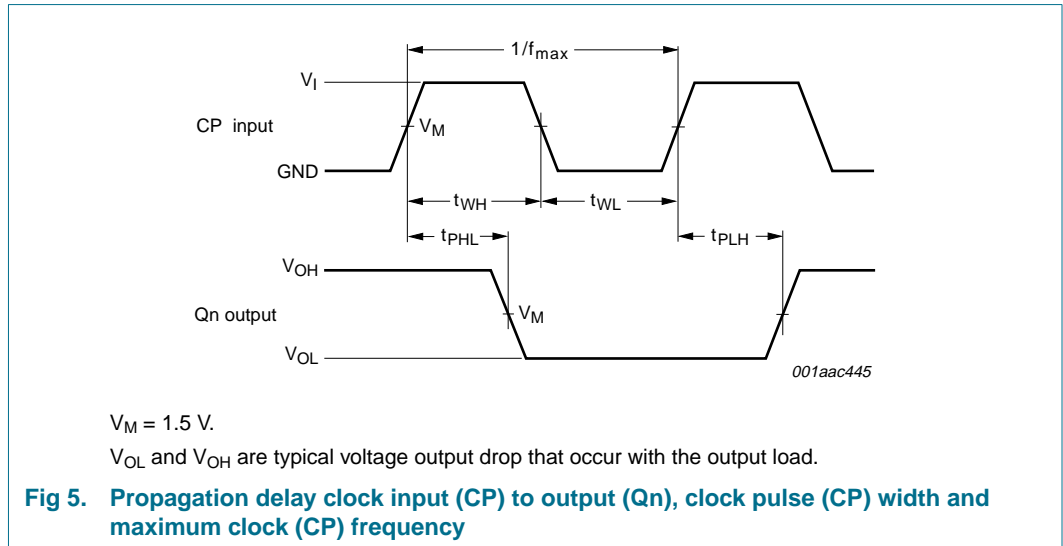

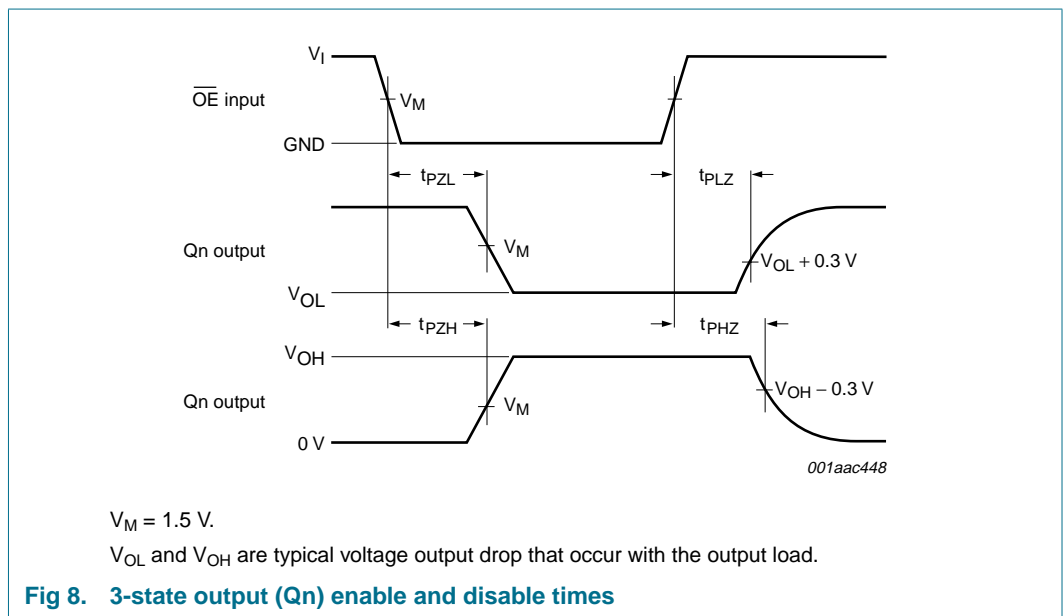
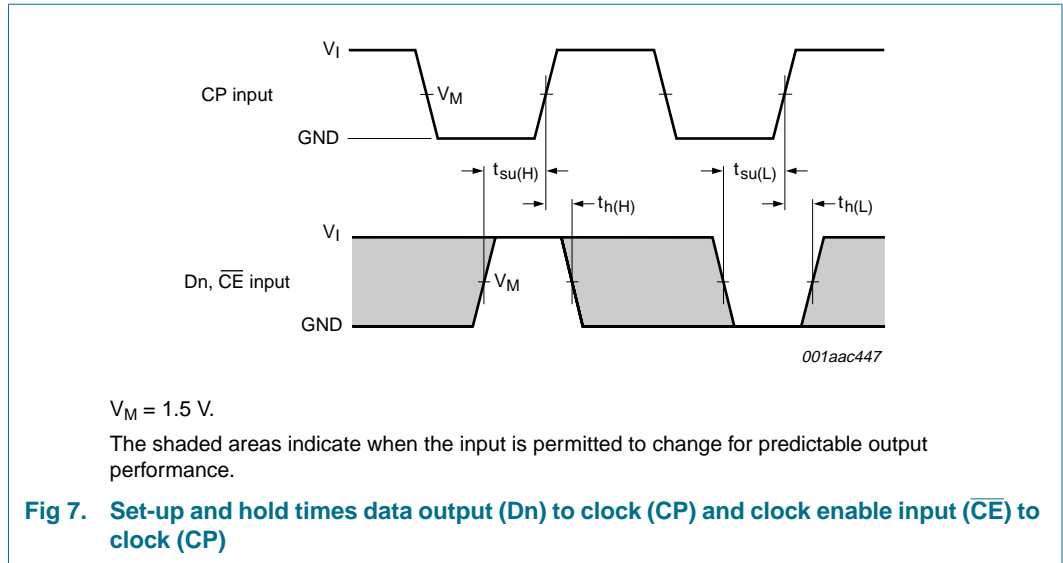

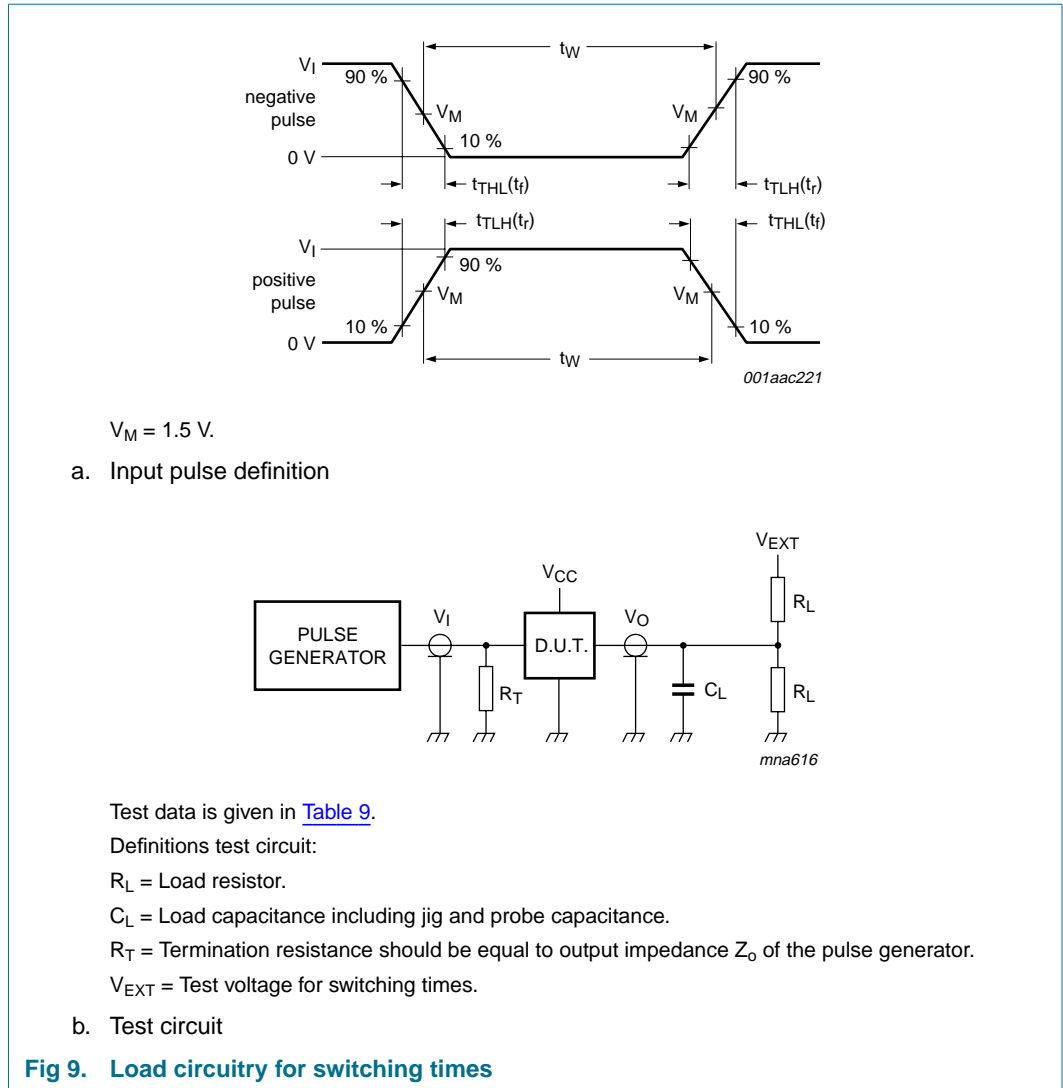

Table 9: Test data

Input				Load		V_{EXT}		
V_I	f_i	t_w	t_r, t_f	C_L	R_L	t_{PHZ}, t_{PZH}	t_{PLZ}, t_{PZL}	t_{PLH}, t_{PHL}
3.0 V	1 MHz	500 ns	2.5 ns	50 pF	500 Ω	open	7.0 V	open

13. Package outline

DIP24: plastic dual in-line package; 24 leads (300 mil)

SOT222-1

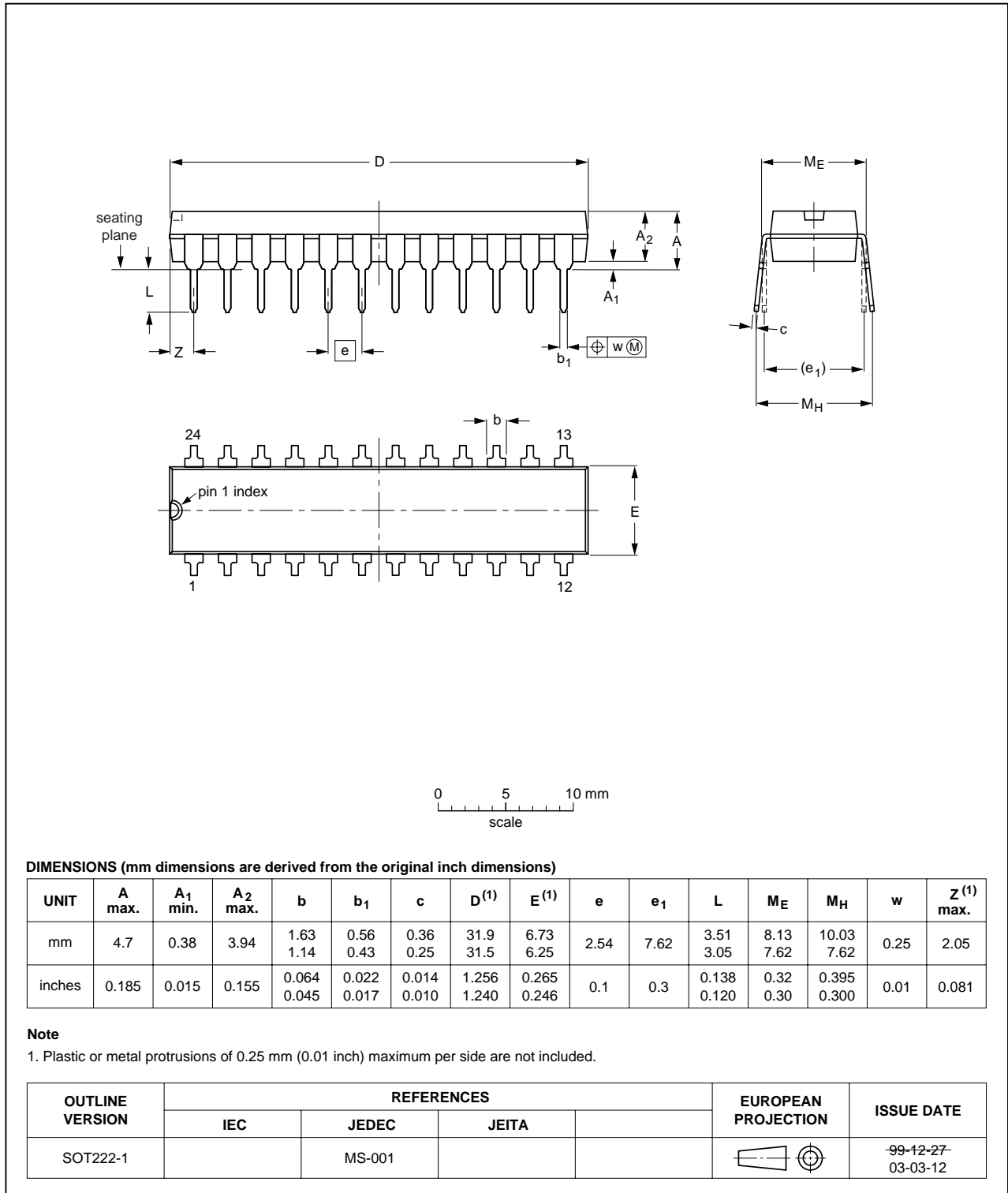

Fig 10. Package outline SOT222-1 (DIP24)

SO24: plastic small outline package; 24 leads; body width 7.5 mm

SOT137-1

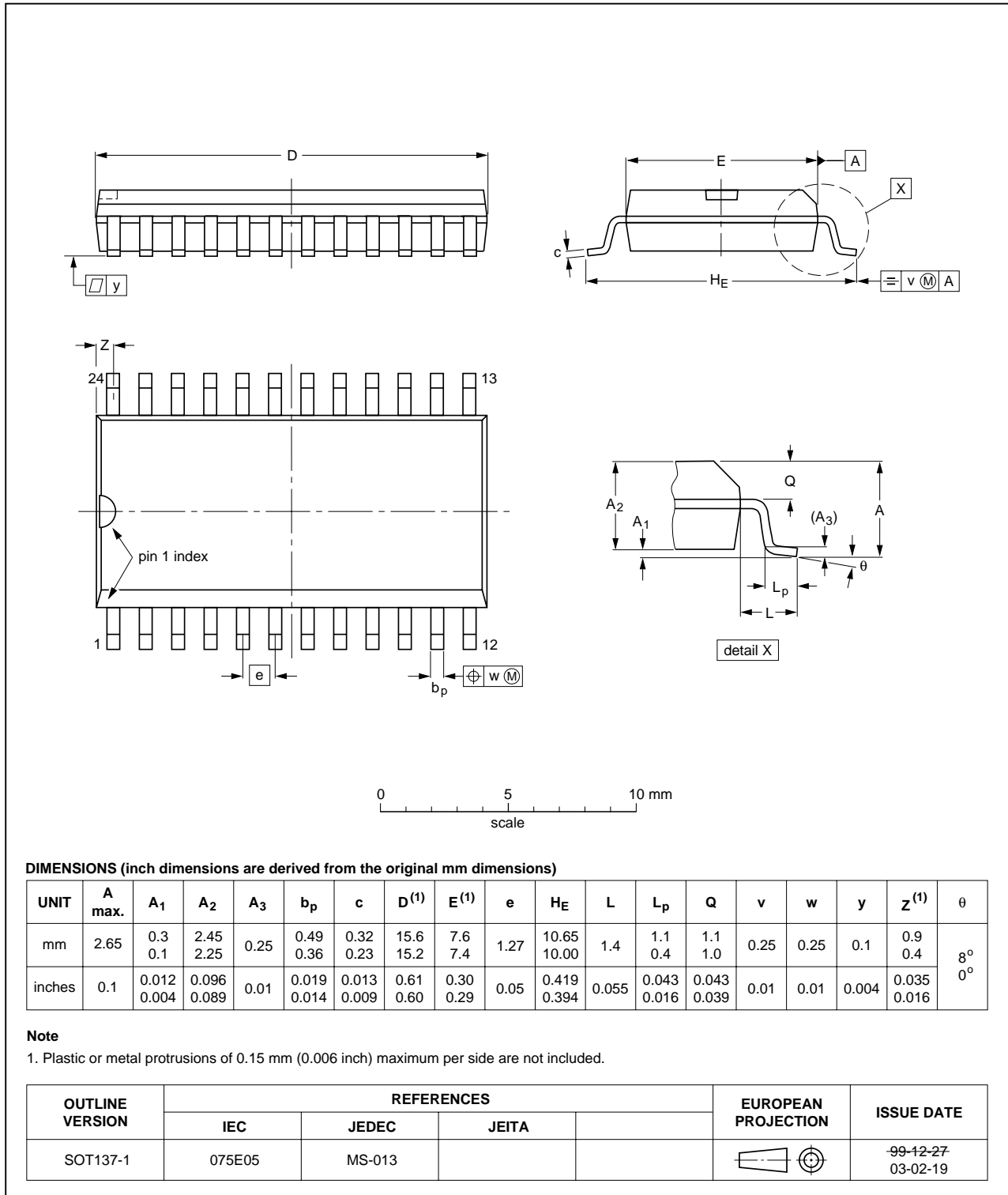

Fig 11. Package outline SOT137-1 (SO24)

SSOP24: plastic shrink small outline package; 24 leads; body width 5.3 mm

SOT340-1

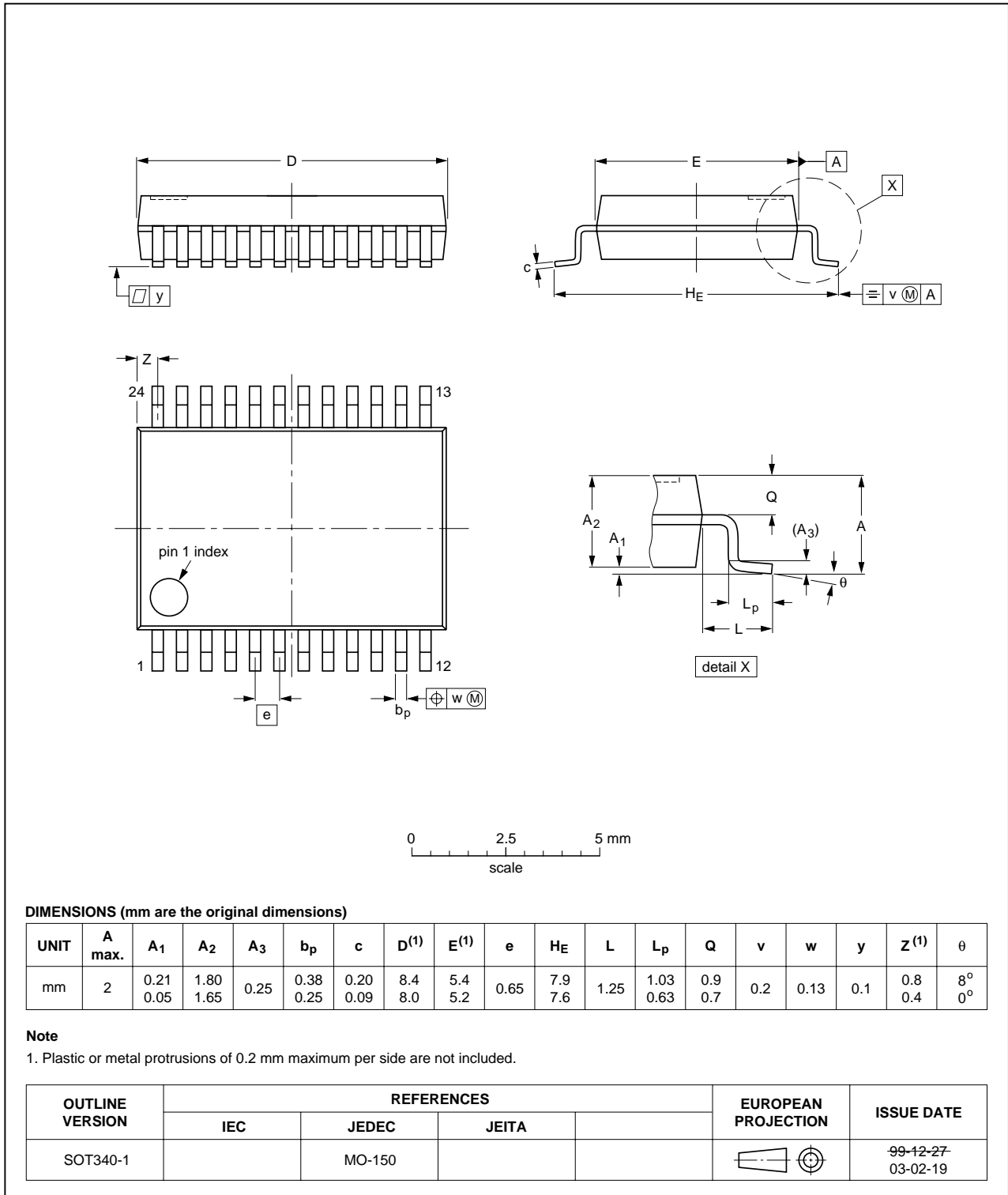

Fig 12. Package outline SOT340-1 (SSOP24)

TSSOP24: plastic thin shrink small outline package; 24 leads; body width 4.4 mm

SOT355-1

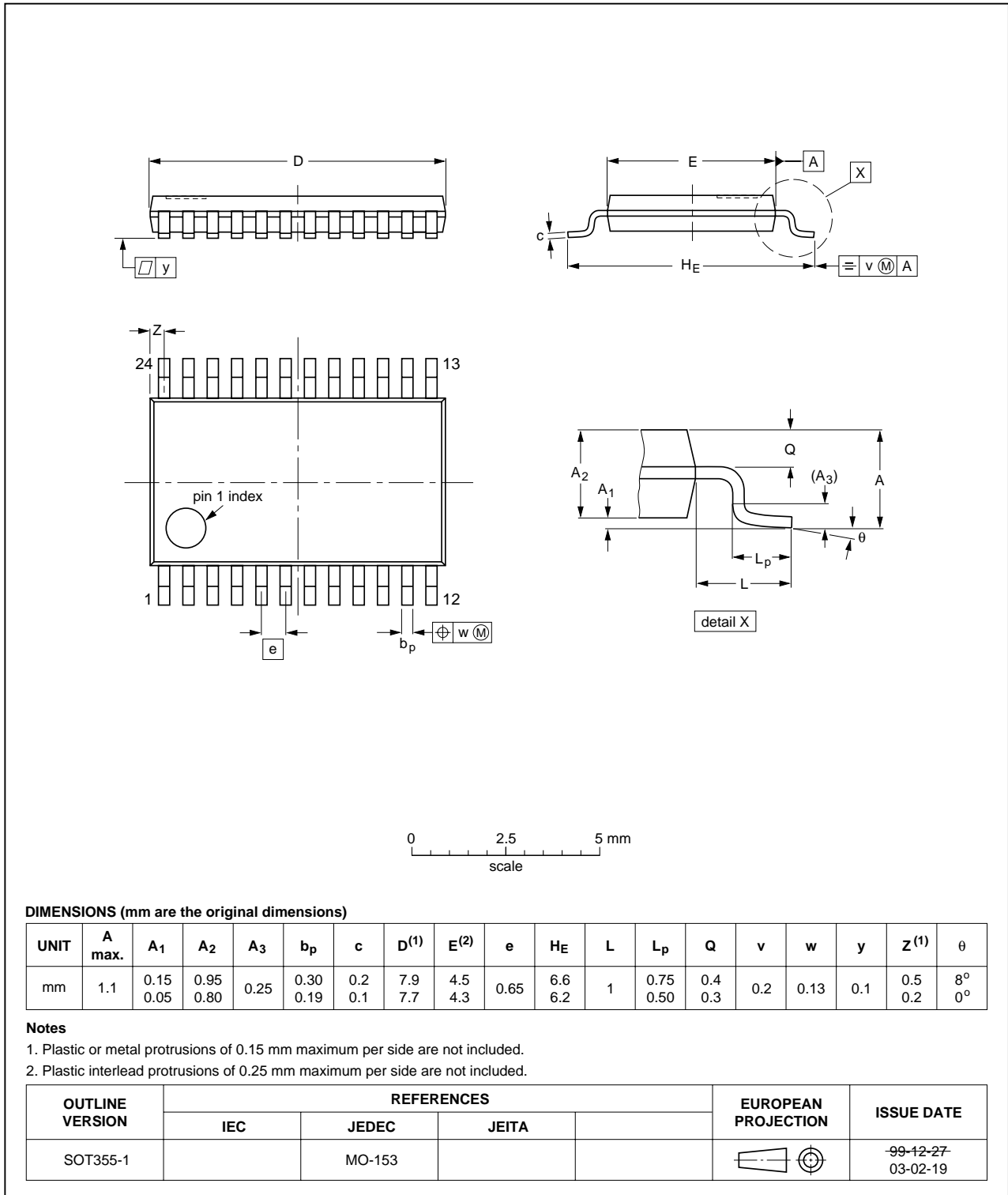

Fig 13. Package outline SOT355-1 (TSSOP24)

14. Revision history

Table 10: Revision history

Document ID	Release date	Data sheet status	Change notice	Doc. number	Supersedes
74ABT823_2	20050207	Product data sheet	-	9397 750 14551	74ABT823_1
Modifications:	<ul style="list-style-type: none"> The format of this data sheet has been redesigned to comply with the new presentation and information standard of Philips Semiconductors. Section 2 "Features": modified 'JEDEC Std. 17' into 'JESD78'. Table 8 "Dynamic characteristics": changed min value of t_{pLZ} from 2.8 ns into 2.5 ns for both conditions at $T_{amb} = 25\text{ °C}$; $V_{CC} = 5.0\text{ V}$ and at $T_{amb} = -40\text{ °C}$ to $+85\text{ °C}$; $V_{CC} = 5.0\text{ V} \pm 0.5\text{ V}$ 				
74ABT823_1	19960314	Product specification	-	-	-

15. Data sheet status

Level	Data sheet status ^[1]	Product status ^[2] ^[3]	Definition
I	Objective data	Development	This data sheet contains data from the objective specification for product development. Philips Semiconductors reserves the right to change the specification in any manner without notice.
II	Preliminary data	Qualification	This data sheet contains data from the preliminary specification. Supplementary data will be published at a later date. Philips Semiconductors reserves the right to change the specification without notice, in order to improve the design and supply the best possible product.
III	Product data	Production	This data sheet contains data from the product specification. Philips Semiconductors reserves the right to make changes at any time in order to improve the design, manufacturing and supply. Relevant changes will be communicated via a Customer Product/Process Change Notification (CPCN).

[1] Please consult the most recently issued data sheet before initiating or completing a design.

[2] The product status of the device(s) described in this data sheet may have changed since this data sheet was published. The latest information is available on the Internet at URL <http://www.semiconductors.philips.com>.

[3] For data sheets describing multiple type numbers, the highest-level product status determines the data sheet status.

16. Definitions

Short-form specification — The data in a short-form specification is extracted from a full data sheet with the same type number and title. For detailed information see the relevant data sheet or data handbook.

Limiting values definition — Limiting values given are in accordance with the Absolute Maximum Rating System (IEC 60134). Stress above one or more of the limiting values may cause permanent damage to the device. These are stress ratings only and operation of the device at these or at any other conditions above those given in the Characteristics sections of the specification is not implied. Exposure to limiting values for extended periods may affect device reliability.

Application information — Applications that are described herein for any of these products are for illustrative purposes only. Philips Semiconductors make no representation or warranty that such applications will be suitable for the specified use without further testing or modification.

17. Disclaimers

Life support — These products are not designed for use in life support appliances, devices, or systems where malfunction of these products can reasonably be expected to result in personal injury. Philips Semiconductors customers using or selling these products for use in such applications do so at their own risk and agree to fully indemnify Philips Semiconductors for any damages resulting from such application.

Right to make changes — Philips Semiconductors reserves the right to make changes in the products - including circuits, standard cells, and/or software - described or contained herein in order to improve design and/or performance. When the product is in full production (status 'Production'), relevant changes will be communicated via a Customer Product/Process Change Notification (CPCN). Philips Semiconductors assumes no responsibility or liability for the use of any of these products, conveys no license or title under any patent, copyright, or mask work right to these products, and makes no representations or warranties that these products are free from patent, copyright, or mask work right infringement, unless otherwise specified.

18. Contact information

For additional information, please visit: <http://www.semiconductors.philips.com>

For sales office addresses, send an email to: sales.addresses@www.semiconductors.philips.com

19. Contents

1	General description	1
2	Features	1
3	Quick reference data	1
4	Ordering information	2
5	Functional diagram	2
6	Pinning information	4
6.1	Pinning	4
6.2	Pin description	4
7	Functional description	5
7.1	Function table	5
8	Limiting values	6
9	Recommended operating conditions	6
10	Static characteristics	7
11	Dynamic characteristics	8
12	Waveforms	10
13	Package outline	13
14	Revision history	17
15	Data sheet status	18
16	Definitions	18
17	Disclaimers	18
18	Contact information	18



© Koninklijke Philips Electronics N.V. 2005

All rights are reserved. Reproduction in whole or in part is prohibited without the prior written consent of the copyright owner. The information presented in this document does not form part of any quotation or contract, is believed to be accurate and reliable and may be changed without notice. No liability will be accepted by the publisher for any consequence of its use. Publication thereof does not convey nor imply any license under patent- or other industrial or intellectual property rights.

Date of release: 7 February 2005
Document number: 9397 750 14551

Published in The Netherlands